

#### AXLES

Front: Rockwell FD-931, 9000 lbs (4082 kg). Chain snubbers.

Rear: Rockwell SLHK tandem, 34,000 lbs (15,422 kg), single reduction. No-spin differential on forward-rear axle.

Ratio — With Ford engine, 7.8:1, total final reduction 118.2:1; with GM engine, 7.2:1, total final reduction 112.2:1.

#### FRAME

Wide-flange beam, 10" (25 cm), 39 lb (17.7 kg), all welded. Channel bumper.

#### SUSPENSION

Front: 12-leaf main spring, 38-1/2" x 3" (98 cm x 7.6 cm); 4-leaf auxiliary spring, 31" x 3" (79 cm x 7.6 cm)

Rear: R-340 series Hendrickson solid mount, 8" (20 cm) oscillation.

#### BRAKES

6-wheel air brake system. Rockwell self-adjusting wedge brakes, front and rear.

Front drums: 15" x 4" (381 mm x 102 mm)

Rear drums: 15" x 7" (381 mm x 178 mm)

Anchorlok spring-set actuators on rear, incorporates emergency and parking brake.

AC Wheel Lock Control anti-skid system.

Thermostat-controlled automatic heated spitter valves on both air tanks.

12 cfm (5.7 l/sec) compressor.

#### WHEELS

Spoke

Optional: disc wheels, 10-stud, 11-1/4" (29 cm) bolt circle.

#### TIRES

Single front and dual rear.

With Ford engine — 8.25 x 20 10-ply, highway tread

With GM engine — 9:00 x 20 10-ply, highway tread

#### Optional tires:

With Ford engine —

8.25 x 20 10-ply, all-traction tread on rear

9.00 x 20 10-ply, highway tread

With either engine —

9:00 x 20 10-ply, all-traction tread on rear

#### STEERING

Ross, integral hydraulic power steering.

#### ELECTRICAL SYSTEM

With Ford engine: 12 volt, 60 amp alternator, 95 amp battery, transistorized regulator.

With GM engine: 12 volt, 62 amp alternator with integral regulator, 225 amp battery.

#### COOLING SYSTEM

Fin and tube type radiator, with fan shroud. Five-blade fan.

Fan size: Ford engine 20" (51 cm), GM engine 22-1/2" (57 cm)

#### FUEL SYSTEM

50-gal (189 l) fuel tank, mechanical fuel pump

Ford engine, fuel filter on engine

330: Holly 2-venturi carburetor with governor

391: Holly 4-venturi carburetor with governor

GM engine, primary and secondary fuel filters.

#### AIR FILTER

Dry type air cleaner.

#### OIL FILTER

Full flow, replaceable element.

#### GOVERNOR

Mechanical.

#### CARRIER CAB

One-man. Bostrom Wayfarer seat, adjustable fore and aft.

Tinted safety-glass windows. Roll-down windows in door and side, ventilator in cowl.

#### HYDRAULIC REMOTE CONTROL

Carrier powered by upperstructure engine through hydraulic motor and PTO attached to main transmission. Propel, steering, and air brake controls in upperstructure cab. Carrier engine off when hydraulic remote in use.

#### STANDARD EQUIPMENT

Dual sealed beam headlights, tail lights and stop lights, directional signals, identification light cluster on front and rear, 4-way hazard lights, back-up lights, instrument lights. Gauges for oil pressure, water temperature, dual air tank pressures, fuel; voltmeter, tachometer, speedometer, odometer. Heater and defroster, air-operated windshield wiper, bus-type mirrors, wheel and axle wrenches.

#### WEIGHT

Approx. working weight, upperstructure and carrier, 30" (76 cm) excavating bucket, full fuel tanks —

With Ford engine in carrier: 36,605 lbs (16,604 kg)

With GM engine in carrier: 37,185 lbs (16,867 kg)

Includes 3200 lbs (1452 kg) counterweight.

#### OPTIONAL EQUIPMENT

Bostrom T-bar seat in carrier cab, spark arrestors

#### ATTACHMENTS

30" (76 cm) Excavating bucket

24" (61 cm) Excavating bucket

36" (91 cm) Excavating bucket

60" (152 cm) Ditching bucket

30" (76 cm) Pavement removal bucket

8' (2.4 m) Grading blade

4' (1.2 m) Boom extension

Material unloading combination: gooseneck boom extension

with 60" (152 cm) unloading bucket.

Fluid capacities in U.S. gallons. Specifications subject to change without notice.

# G-440

## GRADALL® Hydraulic Excavator

### CARRIER

## Specifications, Operating Ranges



# WARNER & SWASEY

**THE WARNER & SWASEY CO.**  
**CONSTRUCTION EQUIPMENT**  
**SOLON, OHIO 44139**





Shown with 30" (76 cm) excavating bucket

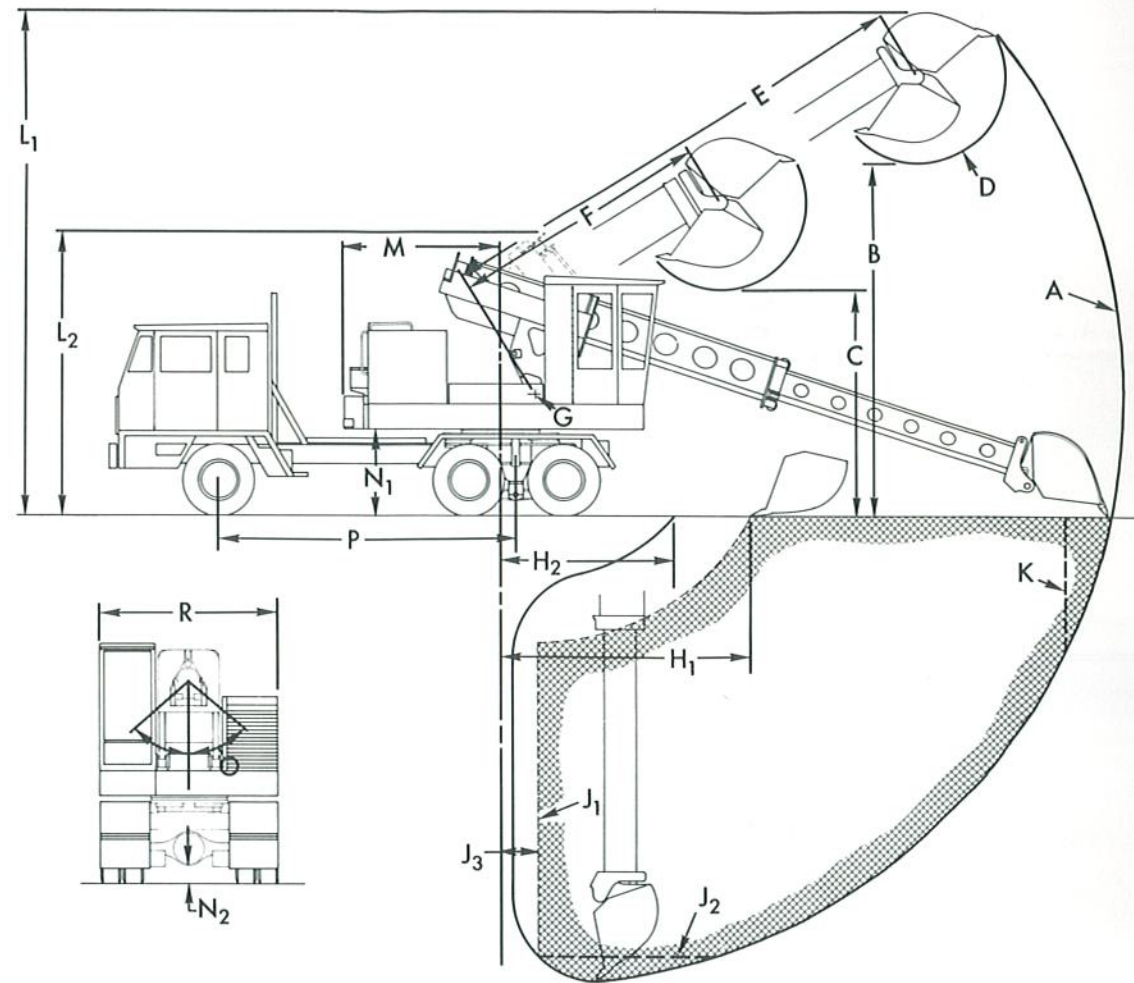

- A – Maximum range  
Reach: 27'8" (8.4 m) at 5'5" (1.6 m) above ground level  
Surface reach: 27'1" (8.3 m)  
Digging depth: 20'8" (6.3 m)
- B – Loading height, boom extended: 15'8" (4.8 m)
- C – Loading height, boom retracted: 10'2" (3.1 m)
- D – Bucket pivot: 170°
- E – Boom length, extended: 22'2" (6.8 m)
- F – Boom length, retracted: 11'8" (3.6 m)
- G – Boom pivot point: 5'5" (1.6 m) above ground level, 1'6" (.5 m) forward from centerline of rotation.
- H<sub>1</sub> – Minimum reach for surface clean-up, bucket level at ground line, boom retracted: 11'2" (3.4 m)
- H<sub>2</sub> – Minimum surface reach, digging: 7'9" (2.4 m)
- J<sub>1</sub> – Level cut range
- J<sub>2</sub> – Maximum depth 8' (2.4 m) level cut: 19'5" (5.9 m)
- J<sub>3</sub> – Minimum radius of level cut range: 2' (.6 m)
- K – Maximum depth of vertical wall cut: 5'9" (1.8 m)
- L<sub>1</sub> – Maximum working height: 22'5" (6.8 m)
- L<sub>2</sub> – Maximum working height with bucket below ground level: 12'6" (3.8 m)
- M – Tail swing: 7'4" (2.2 m)

- N<sub>1</sub> – Upperstructure ground clearance: 3'10" (1.2 m)
- N<sub>2</sub> – Carrier ground clearance: 9" (23 cm)
- O – Boom tilt: 50° each way, total 100°
- P – Wheelbase: 13'4" (4.1 m)
- R – Overall width: 8' (2.4 m)
- Boom raise and lower  
Above ground level . . . . . 32°  
Below ground level . . . . . 90°  
Total arc . . . . . 122°
- Boom telescoping action: 10'6" (3.2 m)
- Swing: continuous
- With 4' boom extension and 30" excavating bucket –  
Surface reach: 31'1" (9.5 m)  
Digging depth: 24'8" (7.5 m)  
Depth of 8' (2.4 m) level cut: 23'6" (7.2 m)  
Loading height, boom extended: 17'10" (5.4 m)

**TRAVEL POSITION  
(Boom in Rack)**

- Overall length: 24'9" (7.5 m)
- Overall width: 8' (2.4 m)
- Overall height: 11'3" (3.4 m)

**UPPERSTRUCTURE ENGINE**

GM 3-53N diesel, 4-valve head, 2 cycle, 85 hp at 2500 rpm, 159.2 cid (2.6 l), 3-7/8" bore x 4-1/2" stroke (98 mm x 114 mm), 17:1 compression ratio, 198 ft-lbs (27.4 mkg) max torque at 1600 rpm, N45 injectors.  
Fuel tank capacity: 60 gal (227 l)  
Electric starter, 55 amp alternator, dry-type air cleaner, oil filter.

**HYDRAULIC SYSTEM**

Three-section tandem pump, flange-mounted to engine, 84 gpm (318 l/min) at 2500 rpm; single-section pump mounted on accessory pad of engine, 10 gpm (38 l/min) at 2500 rpm.  
Five double-acting cylinders:  
2 boom hoist: 5" ID, 2-3/4" rod (127 mm x 70 mm)  
1 telescoping: 4-1/2" ID, 2-3/4" rod (114 mm x 70 mm)  
1 tool: 5" ID, 3" rod (127 mm x 76 mm)  
1 tilt: 4-1/2" ID, 2" rod (114 mm x 51 mm)

One 23 hp hydraulic motor, swing.  
Operating pressure: hoist, swing, tool, tilt 2000 psi (141 kg/cm<sup>2</sup>); boom 1350 psi (95 kg/cm<sup>2</sup>)  
Oil capacity: reservoir 80 gal (303 l), system 115 gal (435 l). Visual oil level gauges on reservoir.  
Filtration system, built into reservoir: 2 filter elements (15 micron) with visual indicators, strainer on by-pass; magnet cluster built into filter housing. Air filter on reservoir breather.  
Fin and tube type oil cooler  
Pump relief valves on all circuits. Hose relief valves on all circuits except travel.

**UPPERSTRUCTURE CAB**

All-weather cab with safety glass windows, skylight, accoustical treatment, heater and defroster. Front window removable, stored in cab.

**UPPERSTRUCTURE CONTROLS**

3 levers, 2 pairs of pedals for all boom and upperstructure movements. Dead-man type are self-centering: when controls are released, machine movements stop automatically.  
2 levers, propel and steer, for control of carrier from upperstructure cab.  
Engine controls: key operated ignition/starter switch with indicator light, throttle. Gauges for engine temperature, oil pressure, air pressure; voltmeter, hour meter.

**CARRIER**

6x4, W/S Model G-434-44  
Wheelbase: 160" (4.1 m)  
Gross Vehicle Weight: 4300 lbs (19,505 kg) axle rating.

**CARRIER ENGINE**

Ford 330 gasoline, 137 net hp at 3600 rpm (operating), 330 cid (5.4 l), 3.875" bore x 3.5" stroke (98 mm x 89 mm), 7.4:1 compression ratio, 250 ft-lbs (34.6 mkg) net torque at 2400 rpm.

Optional – Ford 391, 178 net hp at 3600 rpm (operating), 391 cid (6.4 l), 4.05" bore x 3.875" stroke (103 mm x 98 mm), 7.2:1 compression ratio, 316 ft-lbs (43.7) net torque at 2400 rpm.

Optional – GM 6V-53N diesel, 191 net hp at 2800 rpm (operating), 318 cid (5.2 l), 3-7/8" bore x 4-1/2" stroke (98 mm x 114 mm), 17:1 compression ratio, 405 ft-lbs (56 mkg) net torque at 1700 rpm.

**TRANSMISSION**

Main transmission: 5 speeds forward, 1 reverse, synchronized in 2nd through 5th speeds.  
With Ford engine – Spicer CM5052-C  
With GM engine – Spicer CM6052-B  
Auxiliary transmission: Spicer 7231-D, 3-speed

14" (36 cm) single-plate clutch, Spicer needle bearing universal joints

**Travel speed – mph (km/hr):**

With Ford engine

Aux. Trans.	Main Transmission				
	1st	2nd	3rd	4th	5th
Low	3 (4.8)	6 (9.7)	10 (16.1)	17 (27.4)	24 (38.6)
Direct	7 (11.3)	12 (19.3)	21 (33.8)	36 (57.9)	51* (82.1)
Overdrive	8 (12.9)	14 (22.5)	24 (38.6)	41 (66)	52* (83.7)

\*With 391 engine only. With 330 engine, maximum speed is 45 mph (72.4 km/hr).

With GM engine

Aux. Trans.	Main Transmission				
	1st	2nd	3rd	4th	5th
Low	3 (4.8)	5 (8)	8 (12.9)	13 (20.9)	15 (24.1)
Direct	6 (9.7)	10 (16.1)	17 (27.4)	28 (45.1)	45 (72.4)
Overdrive	7 (11.3)	12 (19.3)	19 (30.6)	33 (53.1)	52 (83.7)

**G-440 GRADALL RATED LIFT CAPACITY OVER END OR SIDE – Pounds (kg)**

Load Point Height	Load Radius						
	5' (1.5 m)	10' (3 m)	13'3" (4 m)	15' (4.6 m)	20' (6.1 m)	23' (7 m)	Maximum radius
Above Ground Level	15' (4.6 m)			3,200 (1,452)	2,070 (939)		
	10' (3 m)			4,525 (2,053)	2,635 (1,195)	1,985 (900)	1,833 @ 23'5" (831) (7.1 m)
	Boom level 8'3" (2.5 m)			4,680 (2,123)	2,680 (1,216)	2,040 (925)	1,860 @ 23'9" (844) (7.2 m)
	5' (1.5 m)			4,770 (2,164)	2,725 (1,236)	2,070 (939)	1,840 @ 23'11" (835) (7.3 m)
At Ground Level				3,980 (1,805)	2,500 (1,134)	1,897 (860)	1,825 @ 23'3" (828) (7.1 m)
Below Ground Level	5' (1.5 m)		4,330 (1,964)	3,075 (1,395)	2,070 (939)		
	10' (3 m)	5,290 (2,400)	3,245 (1,472)	2,330 (1,057)			
	15' (4.6 m)	5,202 (2,360)	2,640 (1,198)				

The above loads are in compliance with SAE Standard J-1097. They do not exceed 87% of hydraulic lifting capacity or 75% of tipping capacity.

The rated lift capacity is based on the machine being equipped with 3200 lb (1452 kg) counterweight and 8345-6002 30" (76 cm) excavating bucket weighing 620 lbs (281 kg). For other buckets, adjust the listed capacities as follows:  
8345-6003 24" (61 cm) excavating – add 140 lbs (64 kg)  
8345-6006 36" (91 cm) excavating – add 45 lbs (20 kg)  
8345-6001 60" (152 cm) ditching – subtract 15 lbs (6.8 kg)  
8345-6005 30" (76 cm) pvmt. rem. – subtract 30 lbs (14 kg)

The load point is located on the bucket pivot point, including loads listed for maximum radius. Do not attempt to gain additional radius by wrapping the load line around the back of the bucket.

Do not attempt to lift or hold any load greater than these rated values at specified load radii and heights. The weight of slings and any auxiliary lifting devices must be deducted from the rated load to determine the net load that may be lifted.

**CAUTION:** All rated loads are based on the machine being level on a firm supporting surface. For safe working loads, the user is expected to make due allowance for his particular job conditions, such as soft or uneven ground, out of level conditions, side loads, hazardous conditions, experience of personnel, etc. The operator and other personnel should fully acquaint themselves with the Operator's Manual furnished by the manufacturer before operating this machine, and rules for safe operation of equipment should be adhered to at all times.